

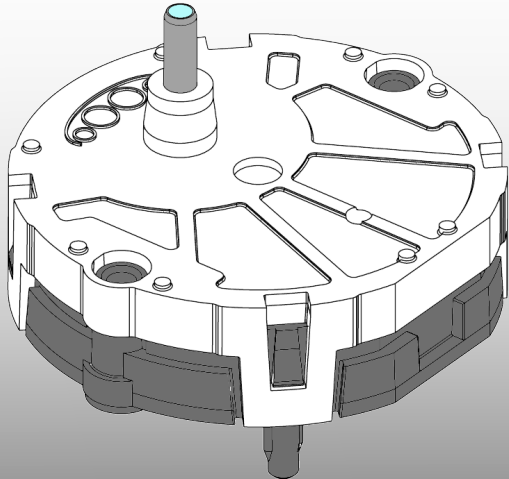

JUKEN Swiss Technology



Automotive instrumentation
stepper motor

X23

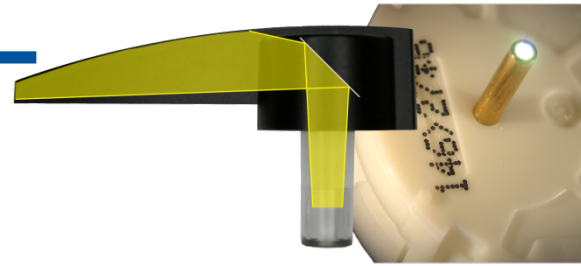

Hollow metallic shaft for optimum
pointer illumination

External light source (single LED)

No lateral light dispersion from
the light guide

Multiple pointer insertion guaranteed
by metal covered light guide

Rear contacts

Dynamic torque [mNm] on shaft

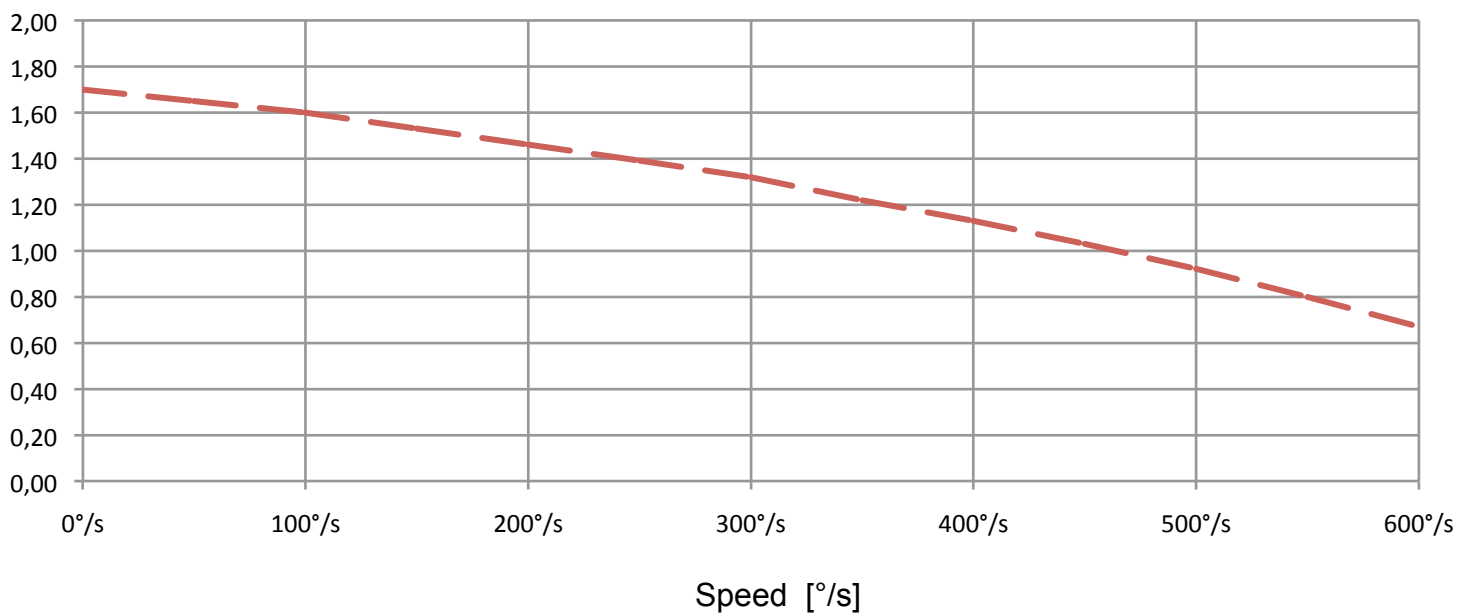

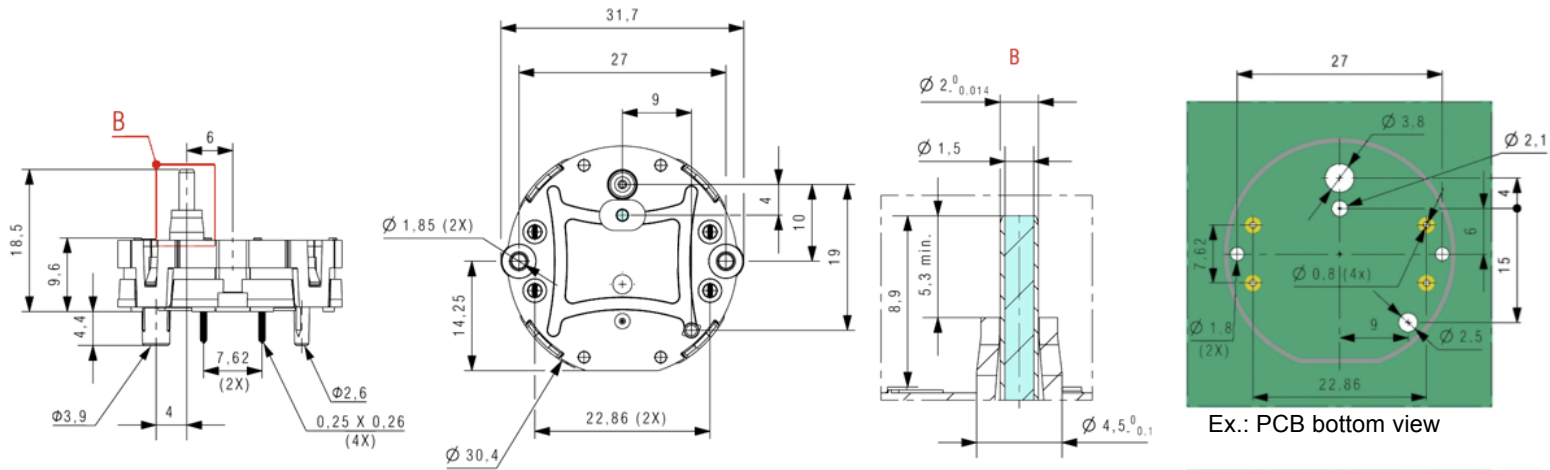

LED model:
 OSRAM PointLED LW P4SG



Ex.: PCB top view (Coils + LED)

$T_{amb} = 25^{\circ}C$

PRELIMINARY

		Min.	Typ.	Max.	Unit
1	Dynamic torque on the pointer shaft at 200°/s and 5.0V _{DC} supply	1.0	1.45		mNm
2	Start-Stop frequency f_{ss} at pointer inertia load $0.2 \times 10^{-6} \text{ kgm}^2$			200	°/s
3	Maximum operating speed f_{max} with an acceleration ramp			600	°/s
4	Angle of rotation with internal stop			315	Degree
5	Holding torque powered	3.5	4.0		mNm
6	Operating voltage		5.0	9.0	V _{DC}
7	Coil resistance per coil	230	260	290	ohm
8	Electrical phase shift between coils		60		Degree
9	Gear play on shaft		0.5	1	Degree
10	Maximum axial force on the pointer shaft			150	N
	Maximum radial force on the pointer shaft			12	N
11	Noise level of the motor, measurement distance 4cm from top of shaft, not mounted, without load, angular speed 300°/s		40		dB(A)
12	Acceleration of sinus vibration test (5..250 Hz), 8h, all directions, at pointer inertia load $0.2 \times 10^{-6} \text{ kgm}^2$		6g		m/s ²
13	Operating Temperature	-40		+105	°C
14	Soldering Temperature (10 sec)		260		°C

